

Algorithmic Sustainable Design: The Future of Architectural Theory.

Nikos A. Salingaros

University of Texas at San Antonio

A series of 12 Lectures, 1 hour each.

This seminar is not an official course, so registration is not required, and no university credit will accrue. Continuing Education credits may be earned for documented attendance, but details will have to be worked out with the AIA.

Description

- *Application of cutting-edge mathematical techniques to architectural design. Fractals and algorithmic processes. Cellular automata that generate the Sierpinski carpet. Harmony-seeking computations. Generative codes, and their difference from static New Urbanist codes.*

Syllabus

- 1. Recursion and the Fibonacci sequence. Universal scaling.
- 2. Fractals and the Sierpinski gasket.
- 3. Universal distribution of sizes.
- 4. Generating a Sierpinski carpet with a 1-D cellular automaton.
- 5. Harmony-seeking computations.
- 6. Alexander's 15 Fundamental Properties.

Syllabus (cont.)

- 7. Biologically-inspired computation and genetic algorithms.
- 8. Emergent systems. Artificial Life.
- 9. Symmetry production and symmetry breaking.
- 10. Generative codes and their application to building and urban morphology.
- 11. DPZ New Urbanist codes and the Transect.
- 12. Implementation of generative codes in design.

Texts

- We will use the monograph “Harmony-seeking computations” by Christopher Alexander, to appear in the *International Journal of Unconventional Computation*, Volume 4, 2008 <www.livingneighborhoods.org/library/harmony-seeking-computations.pdf>. We will also use extracts from Alexander’s “The Nature of Order”, Books 1, 2, and 3 and Stephen Wolfram’s “A New Kind of Science”. Supplemental material will be prepared by the instructor to hand out to students.

Lectures

- Each one-hour lecture will be repeated twice a week. No registration fee is necessary for either lecture. The first time around, it will be offered at Michael G. Imber Architects, 111 W. El Prado St. (right off the McCullough Street roundabout), San Antonio, Texas 78212, on Wednesdays at 12:00-1:00. Seating is limited. First lecture is on Wednesday, January 23, 2008. There is no lecture on March 19, 2008, because of Spring Break.

Lectures (cont.)

- The lecture will be repeated at The University of Texas at San Antonio, (1604 Campus), One UTSA Circle, San Antonio, Texas 78249, Thursdays at 11:00-12:15 Central time, Business Building ITV Room — BB 3.03.02. The Thursday lecture will be transmitted via videoconference to participating institutions throughout the world. First lecture is on Thursday, January 24, 2008. There is no lecture on March 20, 2008, because of Spring Break.

Questions and Feedback

- After each lecture, please feel free to write in questions to me at:
- salingar@sphere.math.utsa.edu
- I will read them and perhaps choose one or more to answer in a subsequent lecture
- Your questions don't have to be in English; try Greek or the Romance languages

Lecture 1

Recursion and the Fibonacci
sequence. Universal scaling.
Biophilia.

Algorithmic design

- An algorithm is a set of instructions that can be followed to achieve a desired, but not always pre-determined end result
- Goes through successive states
- Breaks up the problem into smaller steps
- Sometimes uses recursive feedback
- Contrast with a conception of “all at once”

Design as computation

- We use algorithms to compute a result
- In the absence of an algorithm, we retrieve a result from memory — such computation is therefore based on what is stored in memory
- In architecture, memory of typology influences the results of new designs
- An algorithm makes us independent of memory, hence more creative

Sustainable design

- Use morphogenetic rules that nature follows
- Mimic but not copy physical, and especially biological structures
- The limitations of natural materials constrain built forms to certain geometries
- *Sticking on a solar panel does not connect to the intrinsic geometry of nature!*

Arithmetic Recursion

- A repeated operation with feedback
- Fibonacci sequence:
- Start with the number 1, then add 1
- Continue adding the previous two numbers to obtain the infinite sequence
- 1, 1, 2, 3, 5, 8, 13, 21, 34, 55, 89, 144, ...

Universal Scaling Hierarchy

- We already have the mathematical tools for a fundamental result in architecture
- *“The alternate terms of the Fibonacci sequence are a check for subdivisions in an adaptive design”*
- {1, 3, 8, 21, 55, 144, 377, 987, 2584, ... }

Applications to design. 1. Going up in scale

- Take the smallest built scale, e.g. a step
Then, the next larger scale should be about 3 times that step, the next largest about 8 times the step, the next about 21 times the step, the next about 55 times, etc., going up to the size of the whole building
- The design should try to avoid significant scales in-between these approximate scales

Applications to Design. 2. Going down in scale

- Take the largest built scale, e.g. the building or its main feature. The next smaller scale should be about $1/3$ of the largest dimension, the next smallest about $1/8$ times the largest dimension, the next $1/21$ of the largest dimension, etc., going right down to the size of small details
- There should be no significant scales in-between these scales

The Golden Rectangle

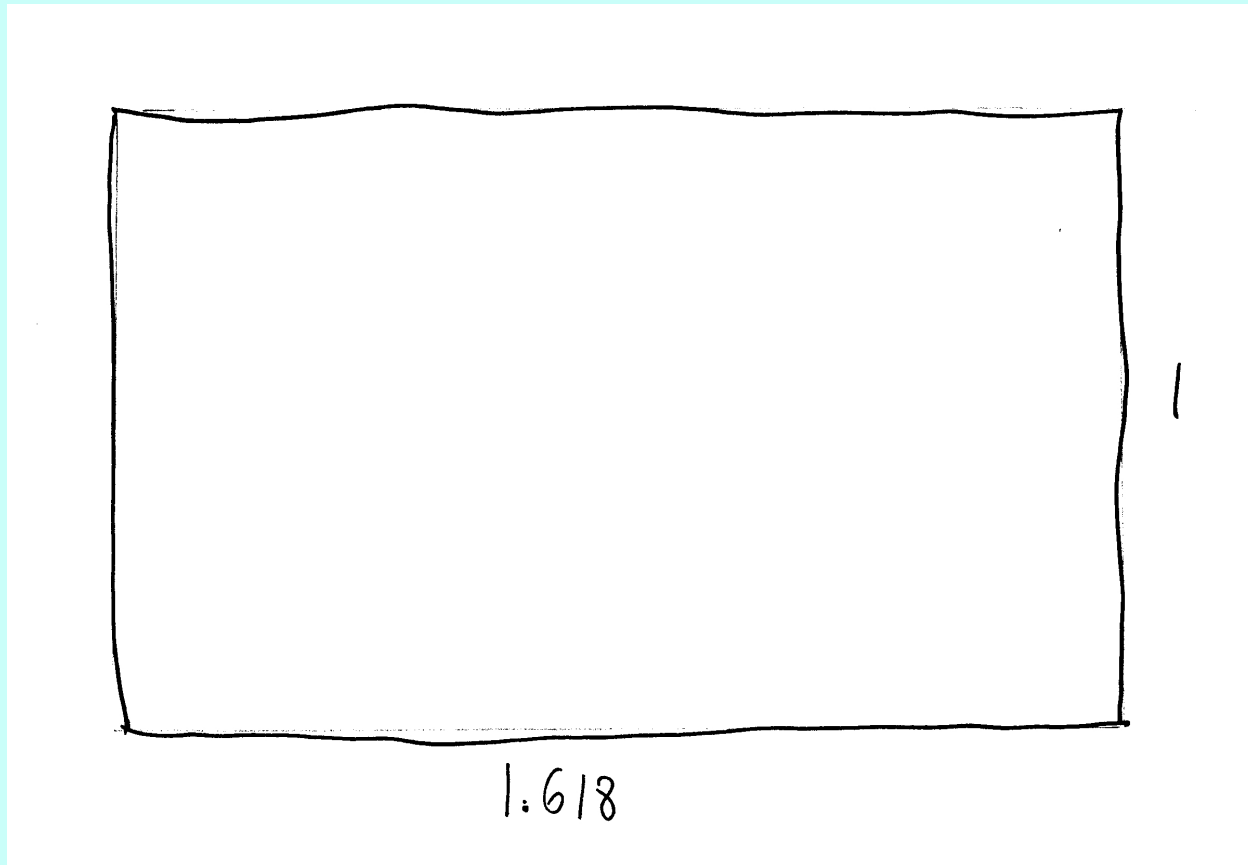

Subdividing into a square plus a vertical golden rectangle

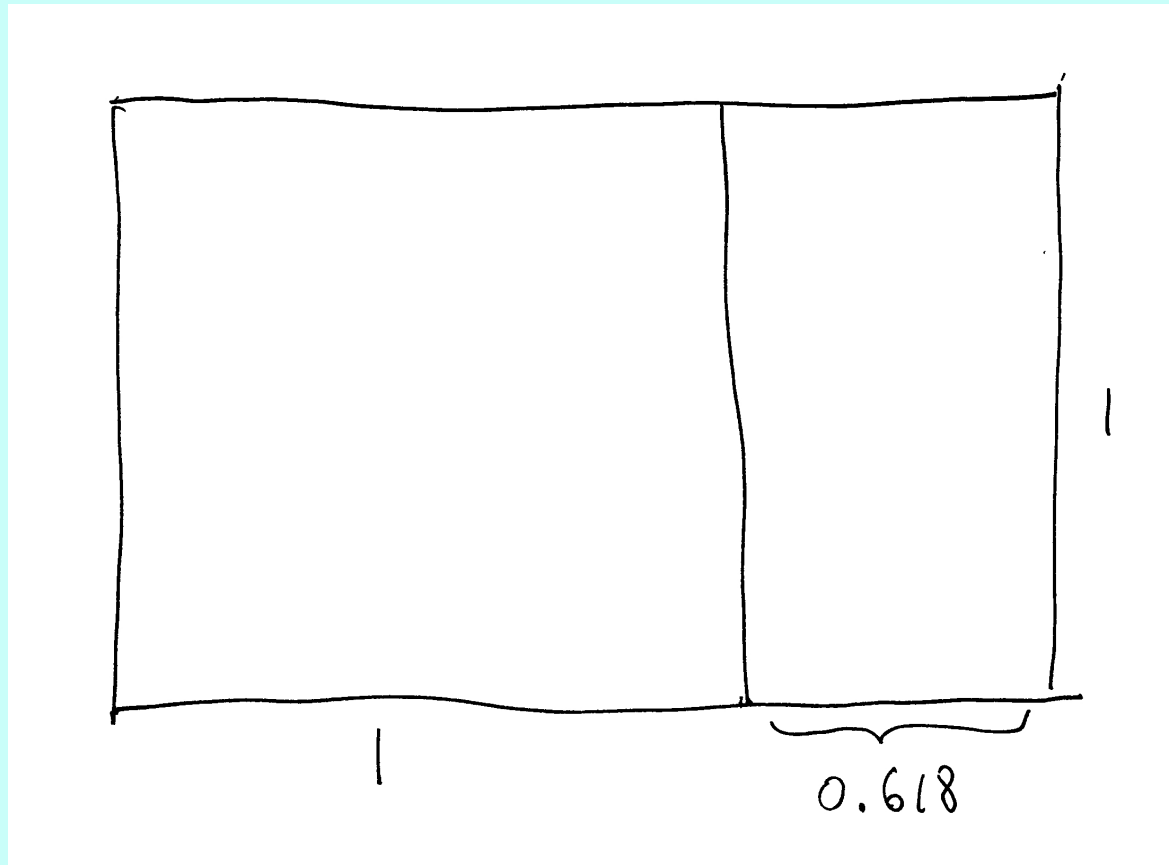

Two subdivisions generate a similar horizontal rectangle

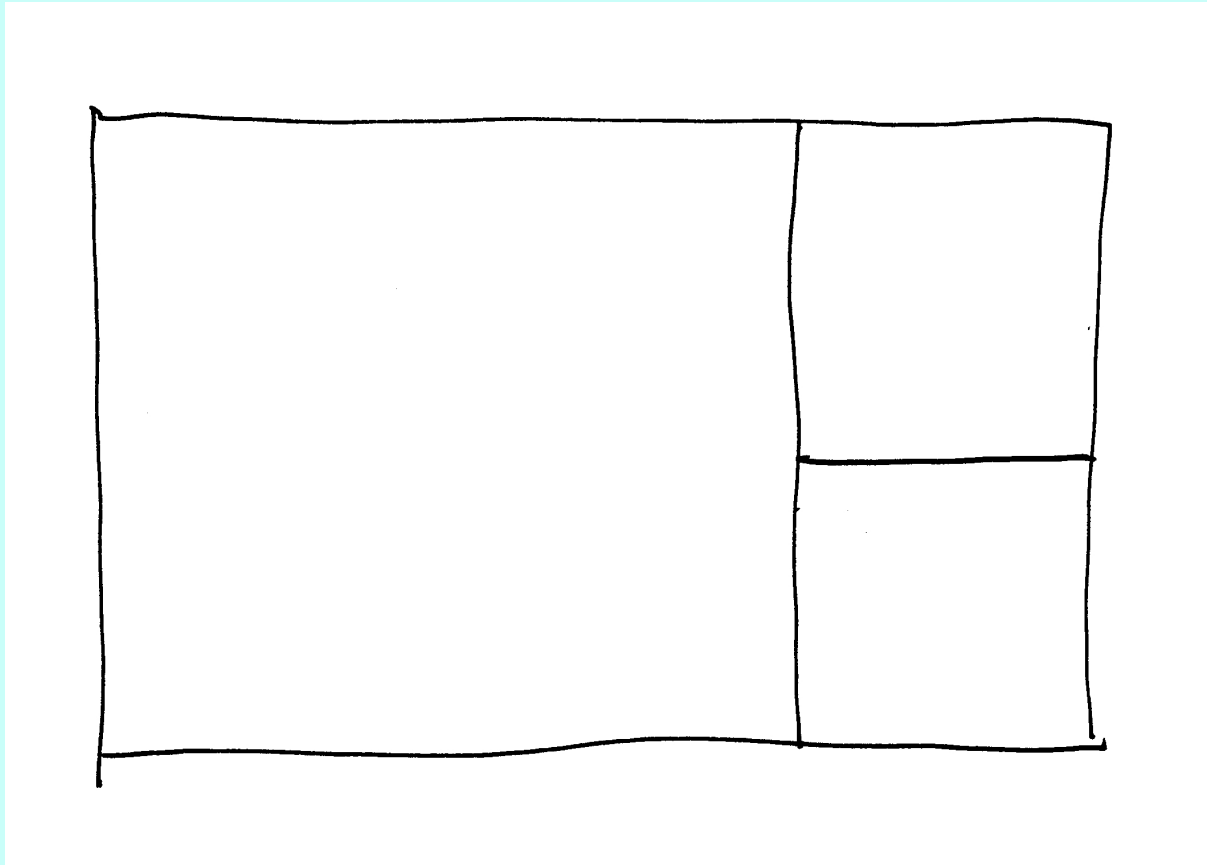

Universal scaling lengths

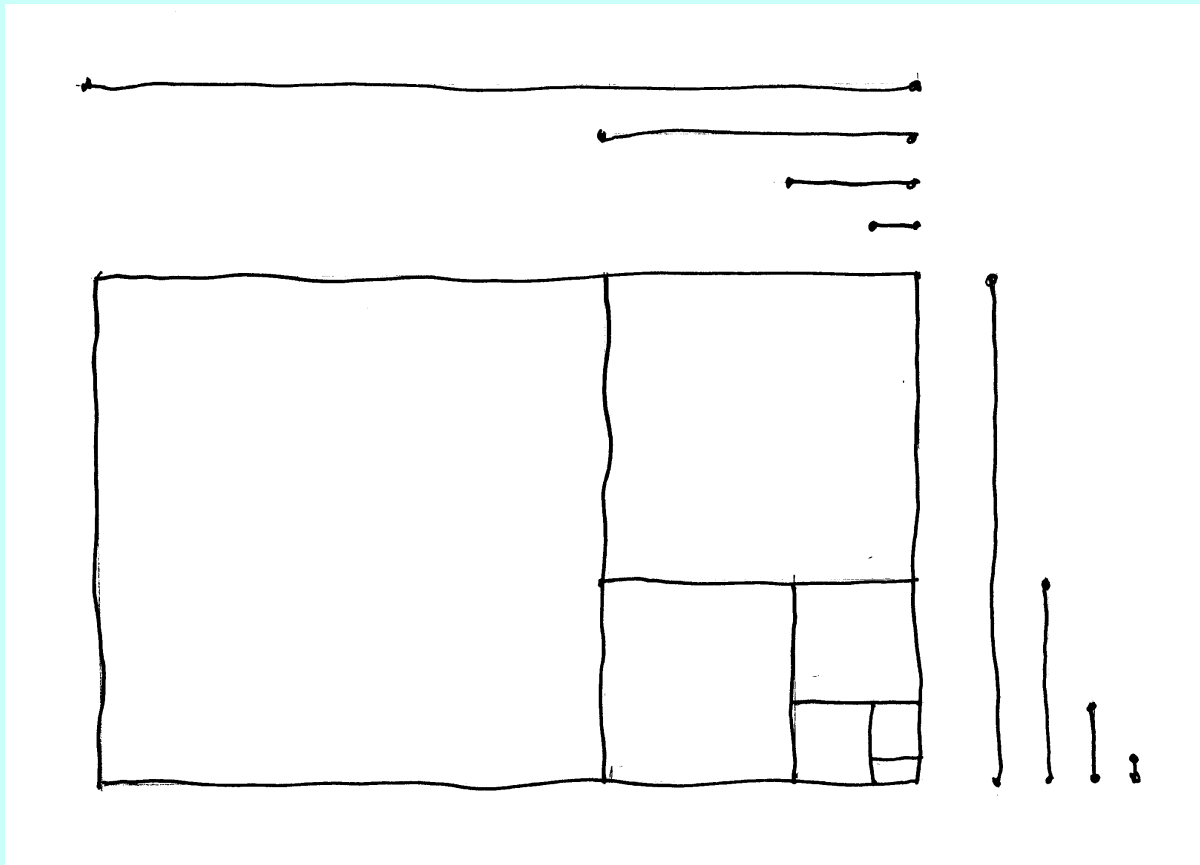

Mathematical scaling ratio

- The limit of the ratio of alternate terms of the Fibonacci sequence as the terms get large is a fixed irrational number, 2.618
- Nevertheless, one cannot use powers of 2.618 instead of the integers 3, 8, 21, 55, etc. to compute the scaling ratios, because the Fibonacci sequence is not a geometric sequence.

The exponential sequence

- Practical tool: use a geometric sequence of powers of the logarithmic constant $e = 2.72$, which determines the shape of animal horns, shells, etc.
- $e^2 = 7.39$, $e^3 = 20.1$, $e^4 = 54.6$, $e^5 = 148$
- This geometric sequence is approximately equal to the universal scaling sequence, but differs in the larger terms

Universal scaling hierarchy

- Extends the old “rule of 3” used in the past, by giving all the other terms
- See “A Theory of Architecture”, *Umbau-Verlag, Solingen, Germany, 2006*: Chapters 2 & 3.
- Develops earlier results by Christopher Alexander in “The Nature of Order, Book 1”, *Center for Environmental Structure, Berkeley, California, 2002*.

Christopher Alexander's *The Nature of Order, Book 1*

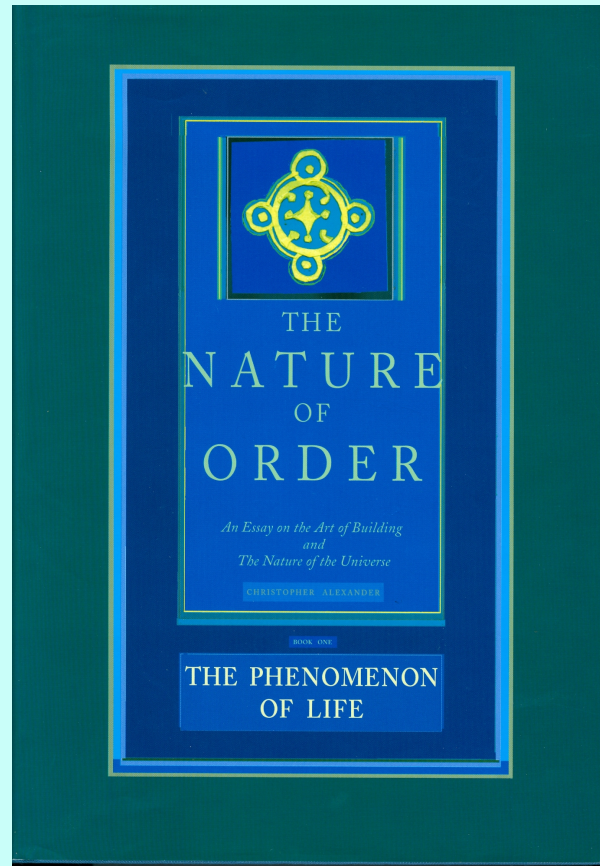

A Theory of Architecture

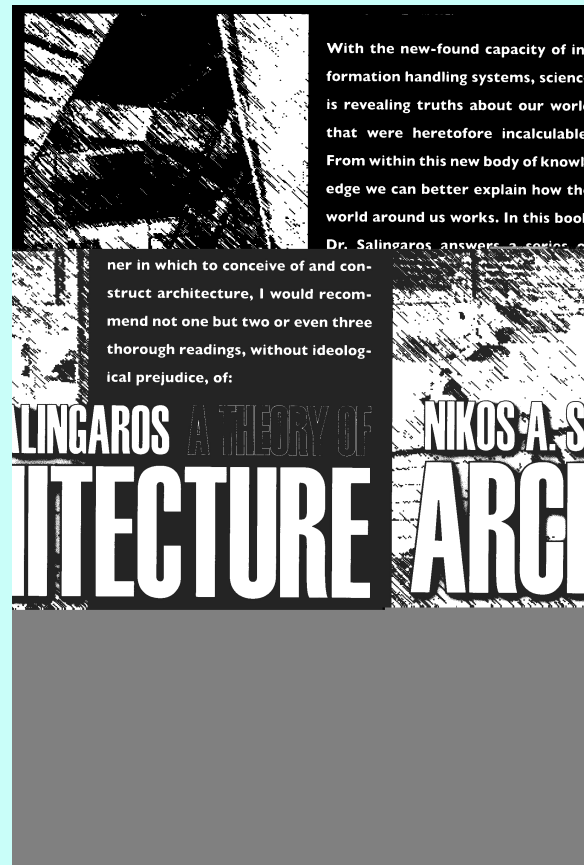

The Golden Mean

- It so happens that universal scaling is related to the square of the golden mean Φ
- $\Phi^2 = \Phi + 1 = 2.618$
- This interesting coincidence has nothing to do with the proportions of rectangles, such as credit cards, the front elevation of the Parthenon, and other buildings!

Architectures that obey universal scaling

- Gothic Architecture
- Classical Western Architecture
- Islamic Architecture
- Vernacular architectures the world over
- Traditional architectures from all cultures and all periods
- NOT international modernism

Masjid-i-Shah, Isfahan

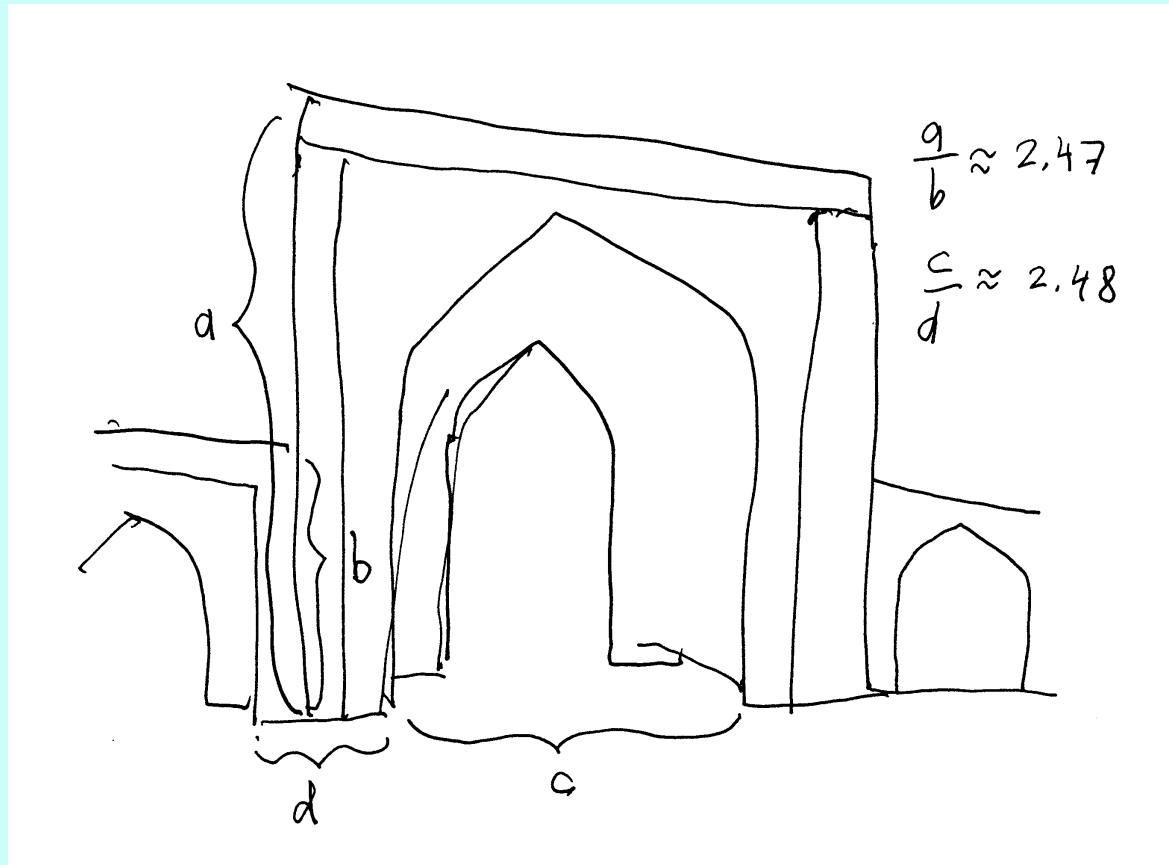

Alhambra, Granada

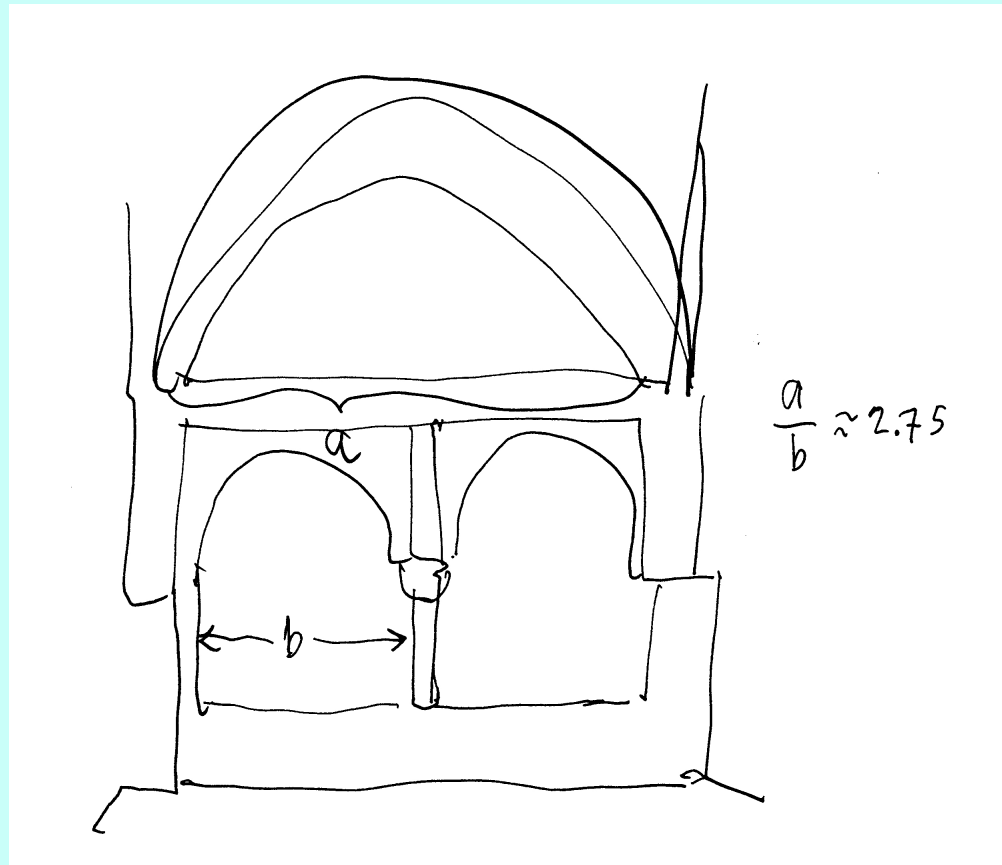

Validation from evolution

- All the cultures we know evolved universal scaling in their indigenous architectures, both vernacular and monumental
- Universal scaling is therefore innate
- The exceptions are military fortifications and the Pyramids, which had to appear unapproachable from the outside

Application to skyscrapers

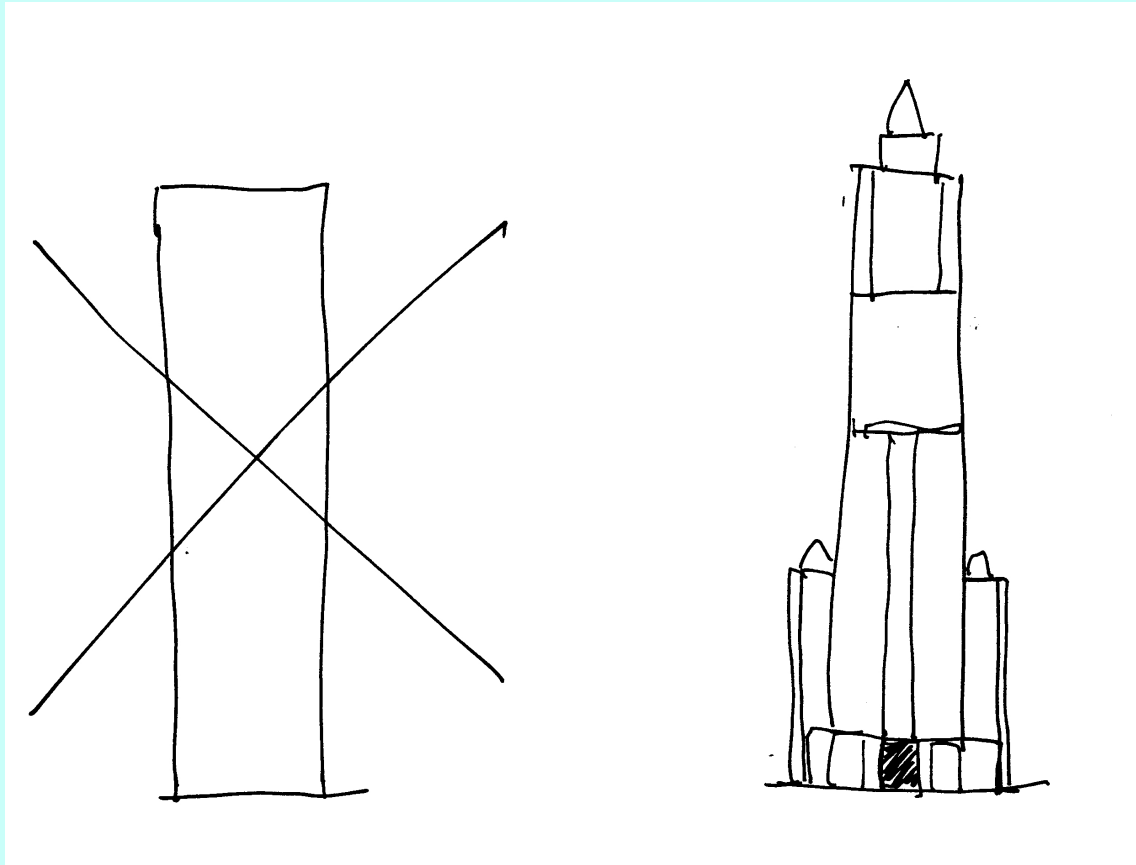

Application to house façades

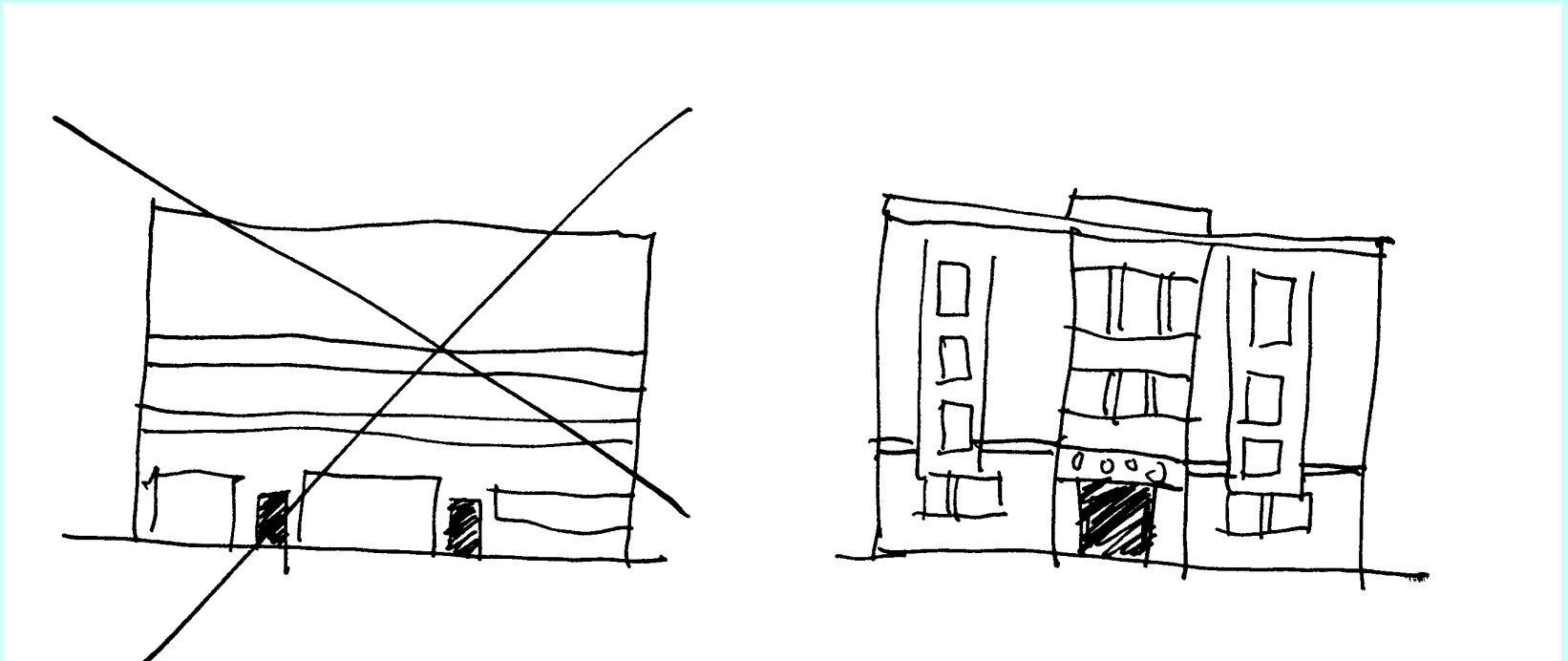

The smaller scales

- The comparison we just did with two residences of roughly the same size and shape is seen on only the larger scales
- But it is on the smaller scales that the difference is really dramatic
- In the modernist house, there are no smaller scales, thus no scaling hierarchy

Magnification

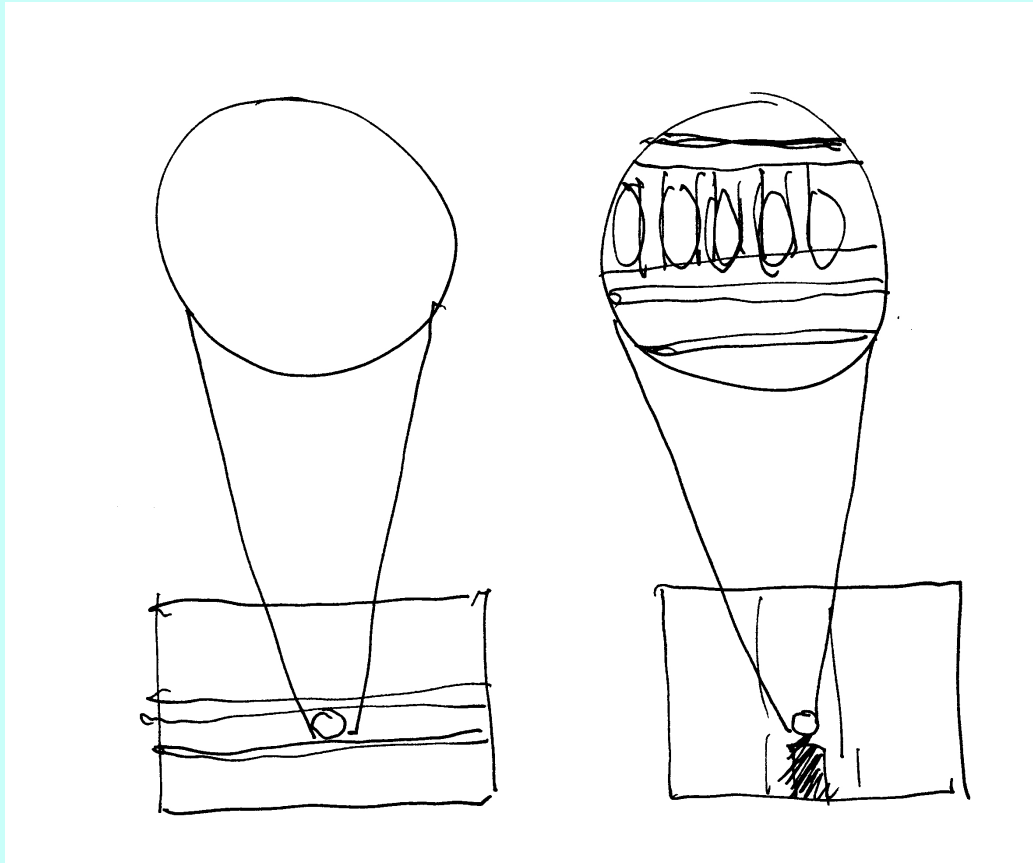

Application: wide boundaries

- An articulation needs its edge defined
- Commensurate with universal scaling, edges or centers should have a lip
- This gives us wide door and window frames, baseboards, pilasters
- There is no longer a need to show off industrial materials without supports

Wide door frame

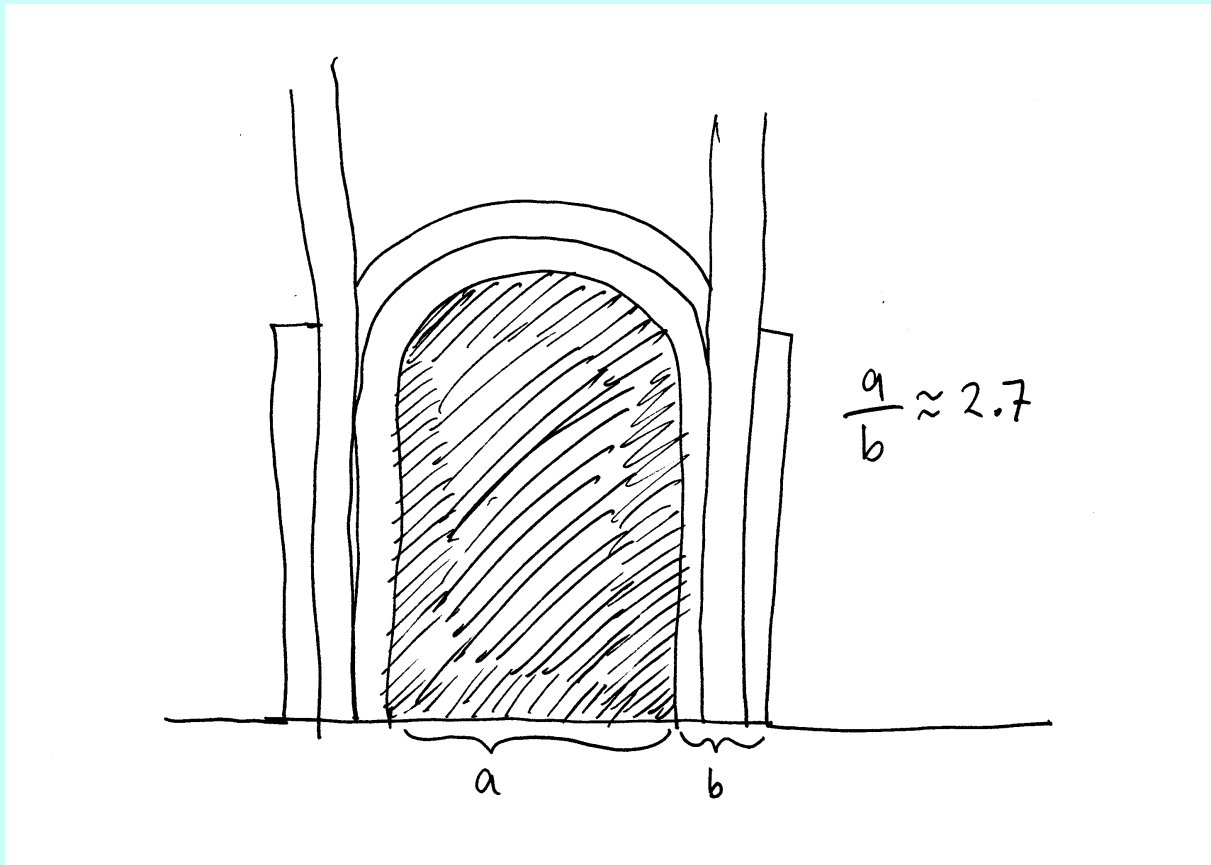

Center follows scaling

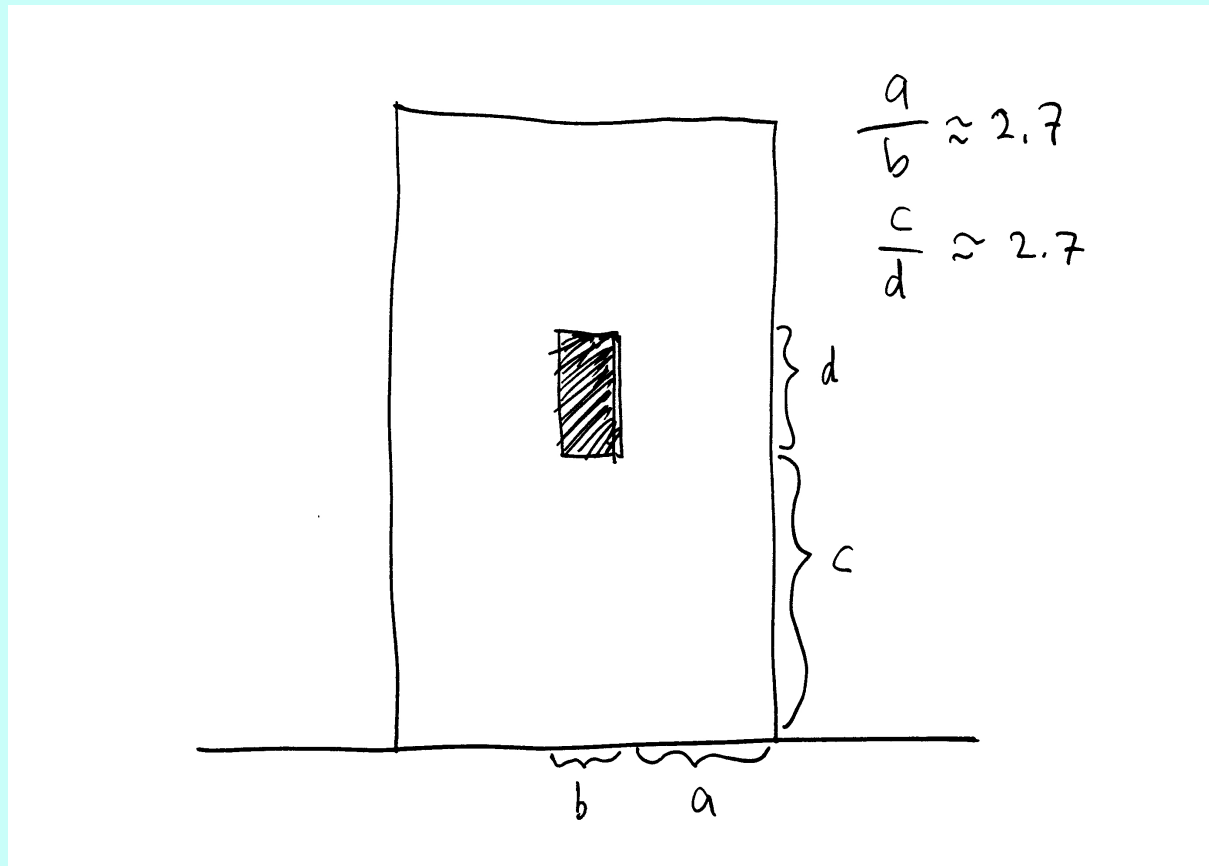

Summary

- Use ratios of lengths to aid design
- Change in thinking about “proportion”
- *NOT* the ratio of the sides of a rectangle, but compare instead dimensions of objects *measured along the same direction*
- Nothing magical or mystical about this

What is Biophilia?

- Edward O. Wilson used the term to describe an innate connection between all living beings
- More specifically, human beings have a biologically-founded link to other life-forms
- The connection is genetic — it resides in the common parts of our DNA

Human sensory systems

- Have evolved to respond to natural geometries of fractals, colors, scaling, symmetries
- Fine-tuned to perceive positive aspects (food, friends, mates) and threats
- Also fine-tuned to detect pathologies of our body, signaled by the departure from natural geometries

Biophilia and Health

- Human beings require contact with the geometry of biological structures
- Experiments in hospitals show much faster post-operative healing in rooms looking out at trees
- Social and mental health deteriorates in nature-less surroundings

Healthy environments

- A healthy mind in a healthy body — which is situated in a healthy environment!
- Positive emotional response to the environment reduces stress and thus raises resistance to disease (external & internal)
- Emotional regeneration: the feelings inside a great Mosque, Cathedral, or Temple

Universal scaling today

- Traditional architects use universal scaling intuitively, but very few people can get this kind of training today
- The memory of Classical architectural typologies is enough to guide the designer doing a traditional Classical building
- The problem is with design *outside* a traditional form language